



IBC PremiumLine

## IBC PREMIUMLINE - AESTHETIC AND EFFICIENT

# IBC MonoSol 240 ET Black, 245 ET Black

## MONOCRYSTALLINE SOLAR MODULES

The IBC MonoSol xxx ET Black meets very high aesthetic and performance standards. Thanks to this black cell, black frame and black back sheet the module matches any rooftop and is suitable for use on single-family homes and even on protected historic buildings. It also produces above-average yields thanks to its monocrystalline 3-busbar technology.

### HIGHLIGHTS

- ❑ Black cell, black frame, black back sheet
- ❑ 25 years linear power warranty\*  
linear power decrease of no more than 0,8 % per year,  
80% / 25 years
- ❑ 10-year product warranty\*
- ❑ Power tolerance -0/+5 Wp
- ❑ Tested according IEC 61215 for snow loads up to 5400 Pa (ca. 550 kg/m<sup>2</sup>)
- ❑ IEC 61730, Application Class A for system voltages up to 1000 V
- ❑ IEC 61215 tested and certified
- ❑ 100% end control with individual registration of the electrical characteristics
- ❑ Quality tested by IBC SOLAR in own laboratory with climate chambers and flasher with integrated electroluminescence measurement

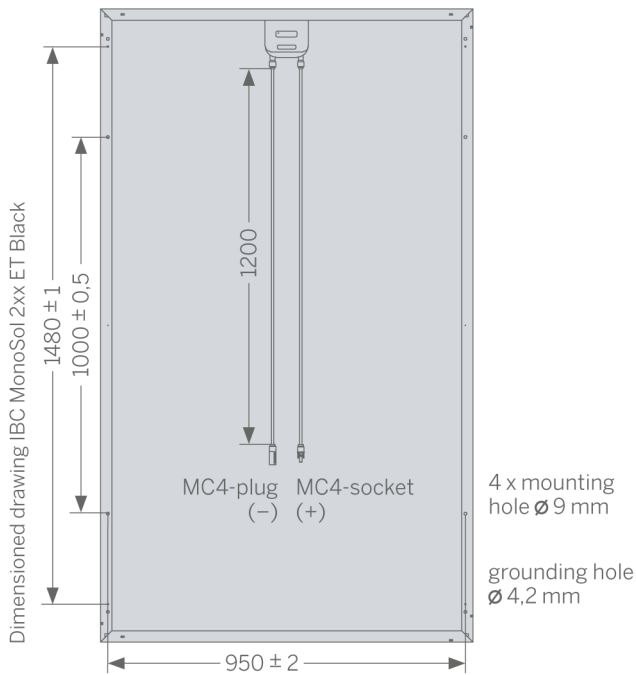

Your linear power warranty advantage

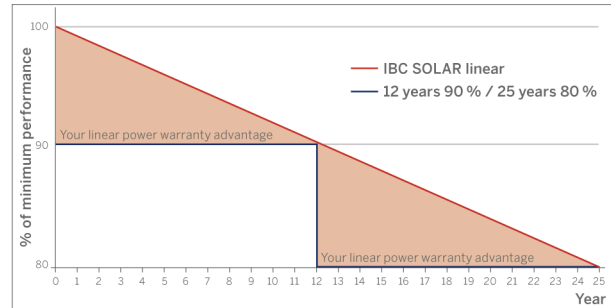

## TECHNICAL DATA

IBC MonoSol	240 ET Black	245 ET Black
STC Power Pmax (Wp)	240	245
STC Nominal Voltage Umpp (V)	30,2	30,3
STC Nominal Current Impp (A)	7,95	8,09
STC Open circuit voltage Uoc (V)	37,4	37,5
STC Short circuit current Isc (A)	8,47	8,50
800 W/m <sup>2</sup> NOCT AM1.5 Power Pmax (Wp)	177	179
800 W/m <sup>2</sup> NOCT AM1.5 Nominal Voltage Umpp (V)	27,7	27,9
800 W/m <sup>2</sup> NOCT AM1.5 Open Circuit Voltage Uoc (V)	34,9	35,0
800 W/m <sup>2</sup> NOCT AM1.5 Short Circuit Current Isc (A)	6,93	6,96
Rel. efficiency reduction @ 200W/m <sup>2</sup> (%)	5,5	6,0
Tempcoeff Isc (%/°C)	0,04	0,04
Tempcoeff Uoc (mV/°C)	-123	-124
Tempcoeff Pmpp (%/°C)	-0,43	-0,43
Module Efficiency (%)	14,4	14,7
NOCT °C	45	45
Max. System Voltage (V)	1000	1000
Current value String fuse (A)	15	15
Fuse protection from parallel strings	4	4
Length (mm)	1680	1680
Width (mm)	990	990
Height (mm)	50	50
Weight (kg)	24,0	24,0
Articlenumber	2001600018	2001600019

Your IBC SOLAR partner:

16.11.2011

\* Product and power warranty in accordance with the version of the full warranty conditions received from your IBC SOLAR partner at the time of installation. This warranty is valid only when the relevant product is installed in accordance with the applicable installation instructions. Subject to modifications that represent progress.